

Research on wireless Deviation Mode of Foundation Pit Surveying System

HU Lei¹, LI Rong-zheng¹, ZAHNG Li-wen¹

(1. School of Electronic and Electrical Engineering, Shanghai University of Engineering Science, Shanghai 201620, China)

ABSTRACT: Aiming at the working principle and measurement method of the active inclinometer which is widely used in the foundation pit engineering, a new automatic inclinometer method is proposed for ZigBee, which is a close-range wireless communication technology. Using the tilt sensor SCA100T, through the DTU data transmission module, the real-time measured data through the microprocessor STC12C5630AD processing sent to the ZigBee network, to achieve the computer's remote monitoring and automatic tilt measurement.

Keywords: foundation pit engineering, ZigBee, remote monitoring

I. INTRODUCTION

Foundation pit engineering as a derivative of the process of modernization is gradually becoming familiar with people. With the rise of foundation pit engineering, the researches the foundation pit construction, support design, safety testing are also actively launched. Compared with the construction and supporting design of the foundation pit, the safety detection as a long-term project, is clear to see the difficulty and importance of its design, the frequent pit damage is also the safety alarm of the pit. Especially in Shanghai, this coastal city, soil moisture content is high, and easy to reach saturation. In the process of foundation pit construction, the bottom of foundation will be softened, and the foundation pit will appear sudden deformation. Among them, Monitoring project of responding to the horizontal displacement of the deep soil has been one of the most concerned monitoring projects in the industry.

This design will start from the basic principles of slipping, to the national foundation pit monitoring requirements for the request, and the latest MEMS technology, automation concepts and ZigBee wireless sensor network technology used in the tilt system, then a new automatic tilt measurement method is proposed. In this paper, the overall design and ideas, related hardware design will be proposed. On the basis of hardware design, software module is designed. The system can achieve the following goals: 1, the effective control of the detection distance of 0.5 meters, the error is less than 1 cm; 2, the system to achieve repeatability error of less than 3 mm; 3, tilt detection error is less than 1 degree.

II. ZIG BEE TECHNOLOGY

In many short-range wireless network standards, ZigBee technology, its design and implementation of the way is no particularly big breakthrough. But compared with Bluetooth, Wi-Fi, it is more suitable for some extreme environments, it is relatively lower power consumption. It can adapt to the conditions without long-term power supply scenarios. For the harsh pit environment, building a wireless sensor network (WSN) with ZigBee is preferred. An interoperable network platform can be composed of up to 65,000 ZigBee sensor modules, so that its communication distance can theoretically be infinitely extended. Each individual module itself can be used as a signal acquisition node, but also as a signal transfer station. In addition, each ZigBee Network Node (FFD) can also connect to multiple isolated sub-node (RFD) wireless connections that do not assume the network information transit task. Since the ZigBee protocol stack is fully open source, this provides designers with greater room for play.

III. SYSTEM OVERALL DESIGN

The system scheme divides the system into the oblique sensing subsystem, the data processing subsystem and the distance wireless communication subsystem. The tilt sensor unit consists of SCA100T biaxial angle sensor, small stepper motor and its drive circuit and short-range wireless communication ZigBee microcontroller and its peripheral auxiliary module. The data processing unit is composed of a short-range wireless communication ZigBee microcontroller and a far-range wireless communication unit DTU. The system block diagram is shown in the figure:

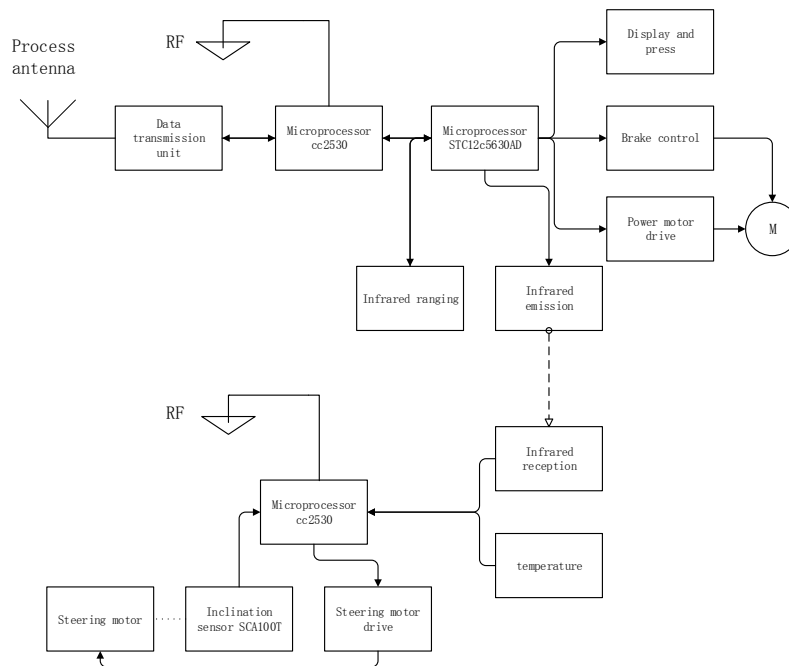

Figure 3.1 system block diagram

3.1 Tilt sensing system

3.1.1 Inclination Sensor

According to the actual demands, the system selects the range of $\pm 30^\circ$ SCA100T-D01. In order to improve the measurement accuracy, the system does not use the SCA100T SPI port to read the internal 11-bit AD conversion results, but using the microcontroller CC2530 12-bit AD conversion SCA100T angle of the analog output voltage, and providing an external reference for the AD conversion of the microcontroller to further improve the measurement accuracy.

Single-chip CC2530 supply voltage is 3.3V, which can accept the highest reference voltage is 3.3V, considering a certain voltage margin, the system uses a 3V reference source. The analog output voltage range of the SCA100T is 0-5V, which exceeds the processing power of the microcontroller AD conversion. Therefore, the output voltage of the SCA100T is divided by the resistor divider, and then it is converted to the voltage range that the microcontroller AD can handle. The voltage after the direct resistance divider can't be directly used for subordinate processing. Because the output impedance of the signal is very high, it is susceptible to interference from the lower input impedance to produce a voltage change. After the partial pressure is added to the follower, the output impedance is reduced, and then it can be fed to the subordinate for AD conversion.

The circuit schematic diagram as shown:

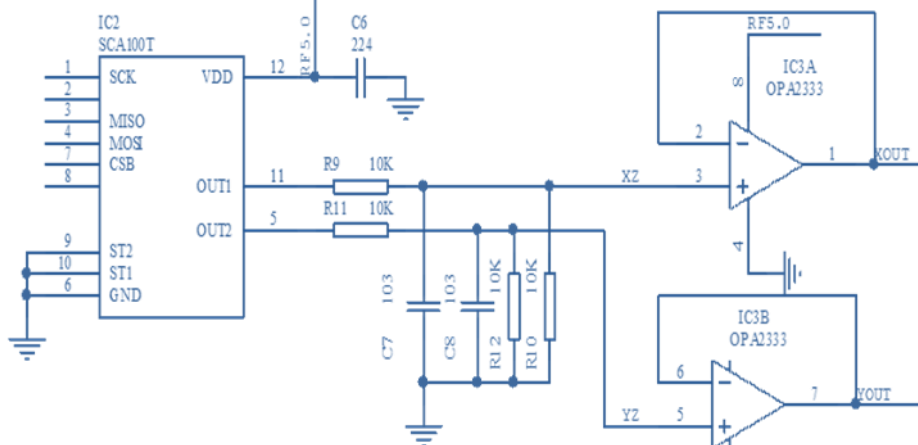

Figure 3.2 Schematic diagram of deviation

3.1.2 Tilting system

The ideal tilt measurement system should strictly meet the "geotechnical engineering monitoring norms" requirements, the price of a reasonable system. Therefore, the reasonable target of the tilting system is: 1. Use an inclinometer to automate both forward and reverse measurements; 2. it has a reasonable measurement of the depth and measurement of the frequency of adaptability, and can be on-site or remote work to set or modify the way; 3. In the absence of an industrial network (AC grid) support or longer unattended period, it achieves energy self-sufficiency and supplements; 4. Achieve measurement data, work mode settings and other remote or remote wireless interaction, to achieve no cable; 5. All the measurement process without interference.

The system requires two parameters: the oblique time interval and the oblique depth. The oblique time interval means the time interval between the two tilting processes. In order to reduce system power consumption, extend battery life, in the interval time the entire system into sleep state. When the system reaches the interval, the system is activated to start the tilt process. After the tilting process is complete, if the system does not receive instructions to change the operating mode, the system will once again enter the sleep, so work again and again. If a new work mode command is received, the system will follow the new instruction and store the work order. The depth of inclination is the longest distance of the inclinometer sensing unit, which represents the depth of the soil tested by the slanting system. The operating parameters of the system can be set and changed by means of the human-computer interface provided by the near-range wireless communication unit and the automatic lift control unit.

3.2 Wireless Transmission System

In the short-range wireless communication microprocessor model this design selected CC2530 microcontroller developed by TI. It is a ZigBee-compatible short-range wireless communication microcontroller, wireless transmission frequency in the 2.4G ISM band In addition to the industry's leading superior RF performance, its CPU is an enhanced 8051 core, in-system programmable flash memory, 8-KB RAM, operating in a single clock instruction cycle, running faster. It also has a powerful peripheral function, including 18 interrupt sources, 8 12-bit AD conversion, 4 timers, a sleep timer, and two USART serial communications. It can be configured as an asynchronous UART or synchronous SPI communication mode. It has a powerful DMA function, as well as 32/64/128 / 256K flash blocks, and it can run in ultra-low power mode, so that the system power consumption to a minimum The CC2530 is capable of building a low-rate, low-complexity, low-power, near-range wireless network at a very low cost and can support multiple network topologies. CC2530 hardware circuit consists of a single chip minimum system and wireless transmission part of the composition. CC2530 hardware circuit is as follows:

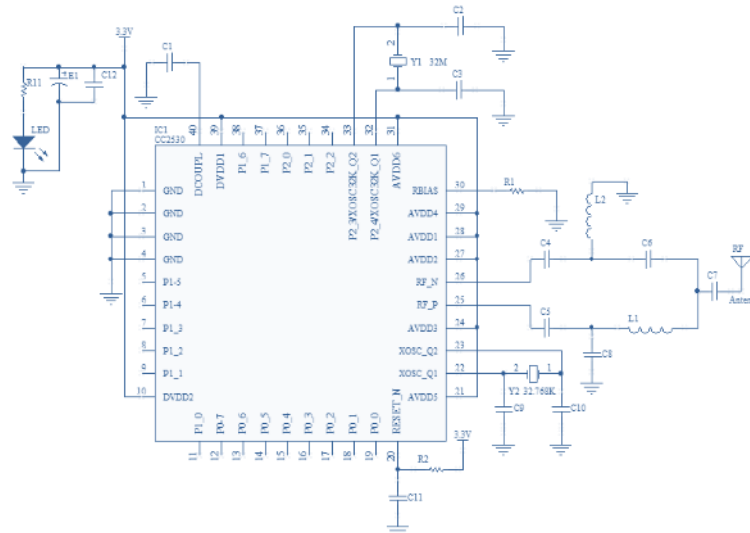

Figure 3.3 CC2530 hardware circuit

IV. SOFTWARE DESIGN

STC12C5630AD mainly to complete the following functions: reset the inclinometer inside the ZIGBEE microcontroller; operations control the power stepper motor; control communication microcontroller CC2530; read DS1302 time. The program flow chart for its work is shown in Figure 4.1:

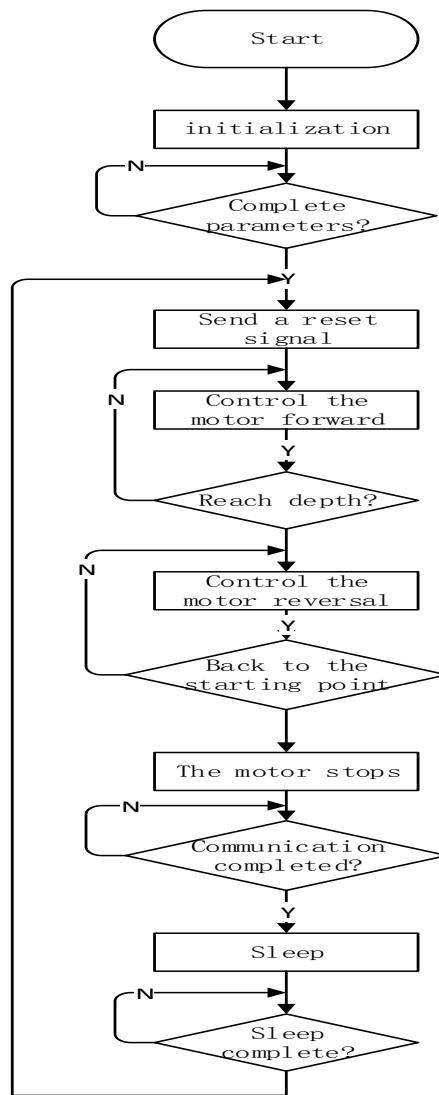

Figure 4.1 STC microcontroller software flow chart

When the microcontroller is powered on, it is initialized first. And then checking the operating parameters of the variable, if there is no operating parameters or operating parameters are not complete, the microcontroller has been in standby mode, when the serial communication through the access to the operating parameters, the end of the wait mode. After getting the operating parameters, the microcontroller sends an infrared reset signal to the tilt sensor unit CC2530, records the time at the moment, and starts timing. 1s after the power stepper motor start, drop down the tilt sensor unit, and start ranging, after reaching 500mm, stop the motor and wait 5s, start the power stepper motor, drop the tilt sensor unit 500mm, stop the motor, wait 5s. According to this way of working cycle, each stop the motor to determine whether the deceleration of the distance to reach the depth of measurement. Each time the motor is stopped to detect whether the drop distance to reach the depth of measurement. If the inclination depth reaches the set position, the steering of the motor changes immediately and the delay is 10s. When the motor is started the next time the motor is turned on. At this time, the tilt sensor unit is raised, each lifting 500mm, pause 5s, and determine whether to reach the beginning of the vicinity of. The Hall position sensor is turned on and the signal is sampled and compared to the stored start position signal, when the sampling signal reaches the start position signal, stop the power stepper motor. After entering the wait state, if the serial port receives a new operating parameter, the operating parameter register is modified. When the communication completion signal of the communication CC2530 is received, the sleep time is set with reference to the operating parameter sampling interval. Turning off unused power and internal functions, the microcontroller will enter the sleep state. Single-chip extracts DS1302 signal regularly, to determine whether the end of sleep. If the sleep is complete, the next measurement process begins.

V. MEASUREMENT CHECK

The calibration of the angle is mainly performed here. CC2530 single-chip is used to sampling SCA100T X-axis output voltage and Y-axis output voltage, since the skew sensing unit has no display portion, the voltage sampled is transferred to the CC2530 using short-range wireless communication. CC2530 sends the data to the LCD module for display, as the picture shows. The tilt angle of the SCA100T is changed while recording the voltage value, and the X-axis output voltage and the Y-axis output voltage of the SCA100T are directly measured with a multimeter. The measured data is shown in the table. As can be seen from the table below, the voltage converted by the CC2530 AD and the voltage phase measured using the digital multimeter are basically the same.

Table 5-1 Comparison of AD conversion voltage and measured voltage

measurement method	X1(V)	Y1(V)	X2(V)	Y2(V)	X3(V)	Y3(V)
multimeter	1.234	2.431	2.383	1.568	3.526	3.593
AD conversion	1.233	2.390	2.382	1.566	3.525	3.592

VI. CONCLUDING REMARKS

Combined with the latest close-up ZigBee wireless communication technology, the author proposes an automatic method of measuring oblique, from the traditional inclinometer on the artificial dependence, to achieve all-weather automated measurement. It not only reduces the measurement error caused by human factors, but also saves time and input costs. The theoretical analysis of the proposed automatic rooting scheme is carried out. According to the engineering application requirements, proposed to improve the inclinometer automatic rise and fall method. At the same time, it can realize the rise and fall of the fixed pitch of the inclinometer choose the related devices and instruments, carry out the hardware design and software design, and do the related simulation experiments; it has a very high practical value.

REFERENCES

- [1]. Yang, Xuelin. Some problems in engineering design, construction and monitoring of foundation pit [J]. Journal of Rock Mechanics and Engineering, 2012, (11): 2327-2333.
- [2]. Wang, Hao, et al. Technical engineering monitoring in large data age - turning and opportunity [J]. Rock and Soil Mechanics, 2014, (09): 2634-2641.
- [3]. Song, Jianjun, Yao Lihui and Liu Yanhui. The present situation and development of deep foundation pit engineering [J]. Journal of Chifeng University (Natural Science Edition), 2009, 25 (3), 33-34
- [4]. Wang, Ruihua and Yu Quan. Analysis of ZigBee technology [J]. Television Technology, 2004, (06): 33-35.
- [5]. Li, Junbin and Hu Yongzhong. Design of ZigBee Communication Network Based on CC2530 [J]. Electronic Design Engineering, 2011, (16): 108-111.
- [6]. Gong, Wenchao, Wu Mengmeng and Liu Shuangxiong. Design and implementation of wireless monitoring system based on CC2530 [J]. Electronic Measurement Technology, 2012, (06): 33-36 + 49.